



Region-specific recombination and expression are directed by portions of the *Drosophila* engrailed promoter.

C Hama, Z Ali and T B Kornberg

Genes Dev. 1990 4: 1079-1093

Access the most recent version at doi:[10.1101/gad.4.7.1079](https://doi.org/10.1101/gad.4.7.1079)

References

This article cites 50 articles, 11 of which can be accessed free at:
<http://genesdev.cshlp.org/content/4/7/1079.refs.html>

Article cited in:

<http://genesdev.cshlp.org/content/4/7/1079#related-urls>

Email alerting service

Receive free email alerts when new articles cite this article - sign up in the box at the top right corner of the article or [click here](#)

To subscribe to *Genes & Development* go to:
<http://genesdev.cshlp.org/subscriptions>

Region-specific recombination and expression are directed by portions of the *Drosophila engrailed* promoter

Chihiro Hama,¹ Zehra Ali, and Thomas B. Kornberg

Department of Biochemistry and Biophysics, University of California, San Francisco, California 94143 USA

The *Drosophila engrailed* gene is expressed in the cells of the posterior developmental compartments. To investigate how the *engrailed* gene is regulated, chimeric genes consisting of fragments of the *engrailed* promoter and *Escherichia coli lacZ* were incorporated into the *Drosophila* germ line by P-element-mediated recombination. Fusion constructs with 7.5 kb of 5'-flanking sequence contain sufficient information to promote expression in most of the embryonic, larval, and imaginal posterior compartments; transformants with smaller fragments of the 5' region do not. Remarkably, of 20 independent transformants with constructs containing more than 1 kb of 5'-flanking DNA, 7 integrated in or around the *engrailed* locus. These strains inactivate *engrailed* function to varying degrees, and some express *lacZ* with a position- and temporal-specific program that is indistinguishable from the normal *engrailed* gene. Presumably, in these strains, *lacZ* is expressed in the context of the *engrailed* promoter.

[Key Words: *engrailed*; region-specific recombination; P element]

Received February 16, 1990; revised version accepted April 24, 1990.

When developmental compartments subdivide the *Drosophila* embryo, posterior compartment cells express the *engrailed* gene, and anterior compartment cells do not (DiNardo et al. 1985; Fjose et al. 1985; Kornberg et al. 1985; Karr et al. 1989). Mutant phenotypes suggest that *engrailed* functions as a developmental switch in these cells: Its presence establishes a posterior developmental state, whereas its absence defines an anterior one (Garcia-Bellido 1975; Morata and Lawrence 1975; Kornberg 1981a; Busturia and Morata 1988; Poole and Kornberg 1988). Position-specific regulation of *engrailed* expression therefore appears to be both simple—either on or off—and essential to its function.

However, the structure of the *engrailed* gene suggests that its regulation is not simple. Its ~4-kb transcription unit is surrounded by extensive flanking DNA that is required for its normal expression (Drees et al. 1987). Mutations that break the genes as much as 15 kb 3' or 25 kb 5' to the transcription unit are embryonic lethal alleles. Breakpoint mutations as much as 20 kb farther upstream also affect its function. In addition, molecular analysis indicates that sequences involved in transcription initiation are present both within the transcription unit and in the sequences immediately upstream and that the flanking regions provide sites to bind many different proteins (Soeller et al. 1988). Consistent with these indications of complex regulation are observations

that *engrailed* expression is dependent on the function of many of the other segmentation genes (Howard and Ingham 1986; Macdonald et al. 1986; DiNardo and O'Farrell 1987; DiNardo et al. 1988; Martinez-Arias et al. 1988). It has been postulated that control of *engrailed* expression involves the superimposition of several regulatory pathways, each of which is established by a hierarchical regulatory network of segmentation genes (for review, see Ingham 1988).

An approach in identifying functional elements in such complex promoters is to link the promoter, or portions of it, to a reporter gene. Gene fusions with the structural gene of *Escherichia coli* β -galactosidase have been used extensively for such studies in *Drosophila*. Here, we describe similar studies with the *engrailed* promoter, in which transgenic flies that harbor gene fusions consisting of the structural gene for *E. coli* β -galactosidase and portions of the promoter were generated. Although the great size of the *engrailed* promoter virtually prohibits the synthesis of chimeric genes with the entire promoter, we found that the most proximal 7.5 kb of the 5'-flanking sequence is sufficient to generate *lacZ* expression in most of the posterior developmental compartments in the embryo. Thus, some of the control elements responsible for position-specific expression are located within this region. Surprisingly, many of the transgenic strains were associated with *engrailed* mutations, lesions that result from the integration of the fusion constructs into and in the immediate vicinity of the *engrailed* gene. Most of these strains express β -galacto-

¹Present address: National Institute of Neuroscience, NCNP, Kodaira, Tokyo 187, Japan.

sidase in the posterior developmental compartments according to the spatial and temporal program of the normal *engrailed* gene.

Results

To identify and characterize the *cis*-acting elements that regulate *engrailed* expression, flies were transformed with gene fusions consisting of fragments of *engrailed* upstream sequences joined with the *E. coli lacZ* gene. Four promoter fragments that include sequences coding for the initial 5 amino acids of engrailed protein, as well as ~1.1, 3.4, 5.7, or 7.5 kb of the sequence immediately upstream of the translation start, were examined (Fig. 1; Table 1). Their introduction into flies was carried out with three different P-element vectors, and *lacZ* expression was monitored either with antibody directed against β -galactosidase or by enzymatic assay. Many of the transformants expressed β -galactosidase at significant levels, and the patterns of β -galactosidase activity varied in a strain- and construct-dependent fashion. Because its patterns accurately mimic the normal developmental profile of the *engrailed* gene, we first describe the patterns expressed in a strain carrying the 5.7-kb construct, *ryxho25*.

lacZ expression with engrailed-like patterns

Expression of β -galactosidase in *ryxho25/+* animals evolved throughout embryonic and larval development in a manner that was robust, patterned, and reproducible and was similar to *engrailed* expression in normal animals. Indeed, β -galactosidase activity in the *ryxho25* strain illustrates the spatial disposition of *engrailed* expression with a precision and clarity that has not been possible previously. The following is a brief summary of this sequence of patterns.

Early during embryo germ-band formation [~3 hr after

egg laying (AEL)], stripes of β -galactosidase protein appeared. They alternated in intensity, with stronger expression in the even-numbered parasegments than in the odd-numbered ones in a manner similar to the expression of *engrailed* (Fig. 2a–d; DiNardo et al. 1985; Weir and Kornberg 1985; Karr et al. 1989). In germ-band-extended embryos, the intensities of the stripes equalized, and a new stripe, lying obliquely, formed in the region of the procephalon. On the basis of its relative position and the fate map of head structures at the extended germ-band stage (Jürgens et al. 1986), we assume that this oblique stripe resides in the antennal segment. After invagination of the stomodeum (~5 hr AEL), a small group of cells dorsal to the cephalic band also accumulated β -galactosidase protein (Fig. 2e,f). As development proceeded, the gnathal lobes were subdivided into two parts by a prominent stripe (Fig. 2g,h; ~10 hr AEL), and during dorsal closure, β -galactosidase-containing cells appeared both in the ventral nervous system (Fig. 2i,j) and in the peripheral nervous system (Fig. 2h). Peripheral nervous system expression was localized to chordotonal organs that extend anteroventrally from the lateral sides of each abdominal segment and in a similar pattern in the thoracic segments, although the identity of these cells was not ascertained. Just prior to completion of dorsal closure, β -galactosidase activity appeared in the developing hindgut (not shown).

Although these patterns are similar to those of *engrailed* protein, there are differences. First, although sensitive antibody probes for *engrailed* protein detect antigen during early nuclear cycle 14 (Karr et al. 1989), β -galactosidase in *ryxho25* was observed only during gastrulation. In addition, *engrailed* protein appeared in the ventral and peripheral nervous systems and in the hindgut at earlier stages than β -galactosidase activity did. We do not know whether detection of β -galactosidase was not sufficiently sensitive at the earlier stages or whether the particular 5.7-kb fusion construct did not

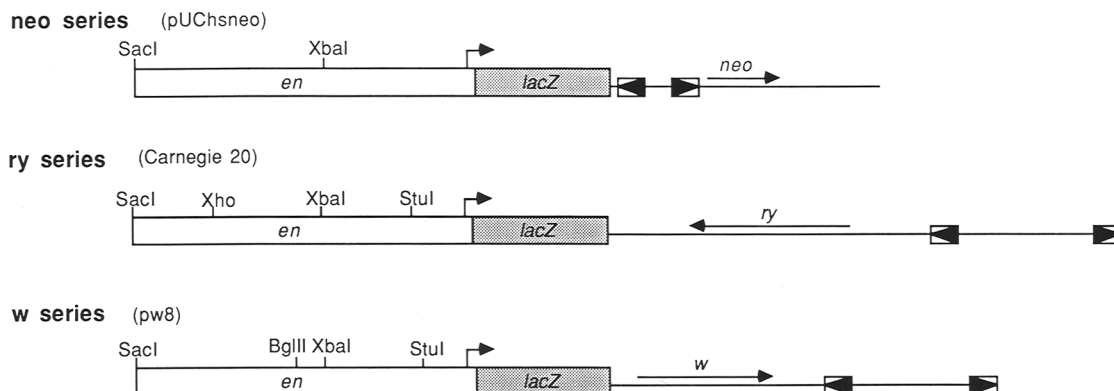

Figure 1. P-element plasmids with *engrailed-lacZ* fusion genes. Plasmids used to transform *Drosophila* were derived from three different vectors. For each vector, a series of *engrailed-lacZ* fusion genes was constructed (see Experimental procedures). For pUCHsneo, *engrailed* promoter fragments extended to either the *XbaI* or *SacI* site indicated. For Carnegie 20, *engrailed* promoter fragments extended to either the *StuI*, *XbaI*, *XhoI*, or *SacI* sites indicated. For pw8, *engrailed* promoter fragments extended to either the *StuI*, *XbaI*, *BglII*, or *SacI* sites. Boxed arrowheads indicate P-element termini, right-angle arrows indicate the site of initiation of the *engrailed* transcript (Soeller et al. 1988); arrows under *neo*, *ry*, and *w* indicate the respective orientation of transcription of these genes.

Table 1. Characterization of 36 different transformants carrying the lacZ gene fused to the 1.1-, 3.4-, 5.7-, and 7.5-kb engrailed 5'-flanking sequences

Strain	Chromosome linkage	Cytological location	Expression in embryonic				Imaginal disc expression
			hpd	hindgut	clypeolabrum	CNS	
1.1 kb							
<i>rystu4</i>	III		–				–
<i>rystu10</i>	II	56F	–				–
<i>rystu11</i>	III		–				–
<i>rystu23</i>	X		–				–
<i>rystu25</i>	II	42B	–				–
<i>rystu27</i>	III		–				–
<i>rystu28</i>	III		–				–
<i>rystu34</i>	II	39C	–				–
<i>rystu37</i>	II	58C-D	–				–
<i>rystu45</i>	III		–				–
<i>wstu9</i>	X		–				–
<i>wstu18</i>	III		–				–
<i>wstu20</i>	X		–				–
<i>wstu32</i>	III		–				–
<i>wstu36</i>	III		–				–
<i>wstu52</i>	II	28A	–				–
3.4 kb							
<i>ryxba21</i>	III		–	–		–	–
<i>ryxba44</i>	III		–	–		–	–
<i>ryxba74</i>	II	55B	–	–		–	–
<i>ryxba82</i>	X		–	–		–	–
<i>wxba9</i>	II	47F	+	–		+	+ ^{a,b}
<i>wxba14</i>	II	34A	–	–		–	–
<i>wxba21</i>	II	48A	+	+		+	+
<i>wxba27</i>	II	26A	–	–		–	–
<i>wxba37</i>	II	24A	–	+		–	–
5.7 kb							
<i>ryxho23</i>	II	48A	+ ^c	+		+	+
<i>ryxho25</i>	II	48A	+	+	+	+	+
<i>ryxho30</i>	II	34E	+ ^d	–	–	+	–
<i>ryxho38</i>	II	49D	–	–		–	–
7.5 kb							
<i>rysac9</i>	II	47F	+	–	–	+	+ ^a
<i>rysac37</i>	III		+	–	–	+	+ ^{a,e}
<i>neosac27</i>	II	48A, 50C	+	–		+	+
<i>neosac71</i>	II	47F	+	–	–	+	+ ^a
<i>wsac16</i>	II	42B	+	–	–	+	+ ^a
<i>wsac35</i>	X		+	–	–	+	+ ^{a,f}
<i>wsac44</i>	III		–	+		–	–

Cytological locations were determined for all insertions into the second chromosomes, and the insertion sites in the 48A region are in boldface type. The embryos were stained with anti- β -galactosidase antibody, and other tissues were stained for β -galactosidase activity. Imaginal discs examined included wing, haltere, and leg.

^aExpression is weak.

^bAdditional anterior compartment expression in antennal and leg imaginal discs.

^cStaining pattern in embryos was normal, but in third-instar larvae, the most anterior row of cells in each adjacent posterior segment also stained, increasing the width of the stripes.

^dThe pattern of alternating stripes persists in germ-band-shortened embryos.

^eBoth the anterior and posterior compartments of the wing and haltere discs stain; expression in the leg discs is posterior-compartment specific.

^fExpression in the leg and antennal discs is not compartment specific.

support efficient expression earlier. We suspect that the latter explanation may pertain, as the fusion construct does not have a polyadenylation addition termination sequence. Second, β -galactosidase persisted in the epidermis of older embryos longer than *engrailed* protein

did. This probably reflects the greater stability of the β -galactosidase protein, because *engrailed* protein in embryos has a half-life of <15 min (Weir et al. 1988), and β -galactosidase is rather long-lived in *Drosophila* (Hiromi and Gehring 1987).

Hama et al.

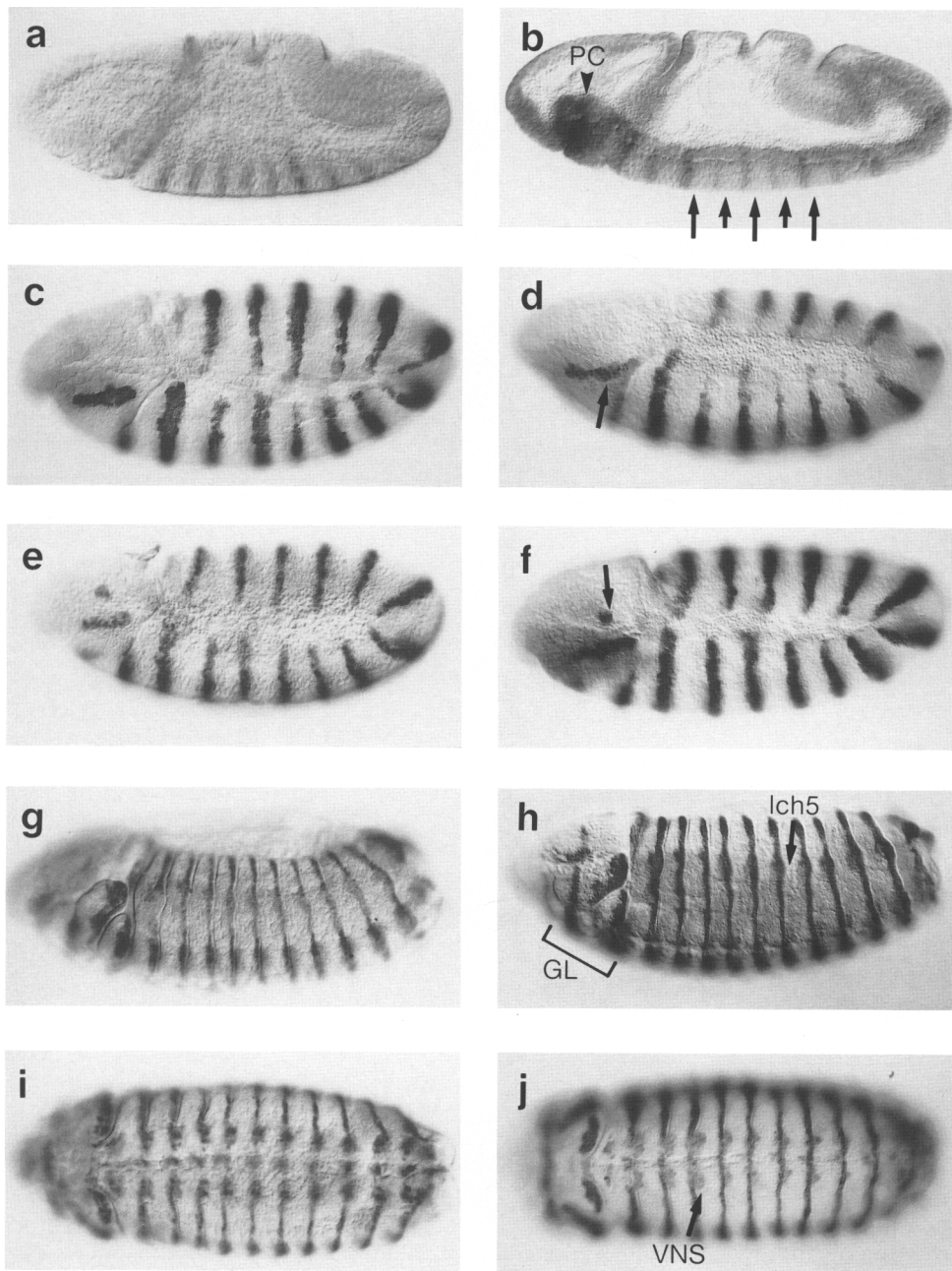

Figure 2. *engrailed* and *engrailed-lacZ* expression in embryos. Patterns of expression revealed by staining of wild-type embryos with anti-*engrailed* antiserum (*a*, *c*, *e*, *g*, and *i*) and *ryxho25* embryos with anti- β -galactosidase antiserum (*b*, *d*, *f*, *h*, and *j*) are similar. (*a* and *b*) Embryos (3 hr) with striped expression of both *engrailed* and β -galactosidase. In *b*, note the alternating intensity of the stripes (arrows); the intense staining in the procephalon (PC, arrowhead) is vector dependent. (*c*–*f*) Embryos 4–6 hr with evenly stained stripes and additional groups of stained cells arranged as an oblique stripe (arrow) and dorsal group (arrow) in the cephalic region. (*g* and *h*) Embryos (10 hr) with germ bands almost fully retracted. The segmental furrows are clearly visible, and stripes are confined to the posterior portion of each segment. A set of peripheral nervous cells (lch5; Campos-Ortega and Hartenstein 1985) in the abdomen protrude anterodorsally from the midlateral site and stain in each thoracic and abdominal hemisegment. (GL) Gnathal lobes. (*a*–*h*) Anterior left and dorsal up. (*i* and *j*) Ventral view of an embryo slightly older than 10 hr. The ventral nervous system (VNS) is clearly stained segmentally along the ventral midline.

Previous studies of normal larvae and adults with probes for *engrailed* RNA or protein, or of genetically mosaic animals did not indicate whether cells of the

larval epidermis express the *engrailed* gene or require its function. These studies also did not resolve whether *engrailed* is expressed in the adult sternites or in the ter-

gites of abdominal segments 2–8. Therefore, the presence of posterior developmental compartments in these tissues was not known. In *ryxho25* animals we find β -galactosidase expression in all of these tissues, suggesting that their posterior compartments are present and that posterior compartment cells express *engrailed*. In the epidermis of first-instar larvae, two principal aspects of β -galactosidase activity were prominent: stripes in each of the segments and an oblique streak in each hemisegment (Fig. 3a,b). The anterior border of the stripes in segments T2 and T3 extended to the Keilin's organs, but apparently not to the dorsal hairs or lateral black dots (Fig. 3a). This is consistent with previous observations interpreting the homeotic transformations induced by *Ultrabithorax* mutations (Struhl 1984). The oblique streaks (Fig. 3b) stain chordotonal projections of the peripheral nervous system. In the abdominal segments, there were no features of the abdominal epidermis marking the anterior borders of the stripes ventrally, but dorsally, the stripes included the faint hairs in segments T2–A2 and the intermediate dark hairs of segments A3–A7 (Fig. 3A). Because of endogenous β -galactosidase activity in the most posterior regions of normal larvae, expression due specifically to the *ryxho25* strain was not determined in these regions. The epidermal stripes were two to five cells wide, and, in abdominal segments 2–8, included the most anterior row of denticle setae on the ventral surface. This observation suggests that the larval segment borders, which coincide with the posterior border of each stripe, are situated ventrally between the first two most prominent rows of setae in each segment. This conclusion is consistent with the designation of Szabad et al. (1979), who mapped mosaic boundaries in sexual mosaics.

In the epidermis of third-instar larvae, β -galactosidase was present in three principal areas: in a bundle of fibers (marking the chordotonal neurons), which lie obliquely to the segmental borders in the anterior portion of the abdominal segments and parallel to them in thoracic segments two and three (not shown), in some of the cells of the histoblast nests (not shown), and in segmentally reiterated stripes (Fig. 3c). The histoblasts are organized into four pairs of nests in each segment and will generate the adult abdominal cuticle after metamorphosis (Roseland and Schneiderman 1979). Counts of preparations from larvae containing a heat shock promoter-*lacZ* fusion gene indicated that the ventral, anterior-dorsal, posterior-dorsal, and spiracle nests had 13–18, 12–19, 6–11, and 3–5 cells, respectively, and that of these cells, 2–5 ventral, 0 anterior-dorsal, 6–11 posterior-dorsal, and 0 spiracle nest cells expressed β -galactosidase in *ryxho25* animals (not shown). Thus, the progenitor cells of the adult tergite (dorsal abdominal cuticle) are subdivided into physically separate groups of cells, one consisting of anterior compartment cells that do not express *engrailed*, and the other of posterior compartment cells that do. This observation is consistent with previous clonal analysis of the A1 tergite, which suggested that the tergites are subdivided by anterior and posterior compartments (Kornberg 1981b). It is noteworthy that

although the posterior compartment stripes of gastrulating embryos are bands with smooth borders, the segmentally reiterated stripes that encircle the larval cuticle have more complex shapes. We presume that these shapes reflect cell movements that contribute to the patterns of the larval cuticle. Like the stripes of the first instar larva, the stripes of the third instar larva include the most anterior rows of the ventral setal belts.

Internal organs of *ryxho25* third-instar larvae also contained β -galactosidase (Fig. 4). Such tissues included the hindgut, ventral nervous system, brain, and posterior compartments of all of the imaginal discs. β -Galactosidase activity in its dorsal half divided most of the larval hindgut longitudinally into two approximately equal parts (Fig. 4d), suggesting that this organ, like all other organs of ectodermal origin, is compartmentalized and expresses *engrailed* in its posterior compartment. This observation was confirmed by staining the hindgut with anti-*engrailed* antibody (F. Maschat and T. Kornberg, unpubl.). The borders delimiting the region of β -galactosidase activity are sharply drawn, separating both the hindgut from the midgut and the anterior from posterior compartment of the hindgut (Fig. 4d). Several aspects of the imaginal disc staining were noteworthy. In the wing, leg, and haltere discs, β -galactosidase expression was consistent with known patterns of *engrailed* expression (Fig. 4a; Kornberg et al. 1985; Brower 1986). In contrast and contrary to predictions from clonal analysis studies (Morata and Lawrence 1979), the eye-antennal disc stained strongly in two discrete regions (Fig. 4b). As expected, one was in the part of the presumptive antenna that includes portions of the three antennal segments and the arista. The other, in the presumptive ocellus, was unexpected and may represent a heretofore unmapped posterior compartment. Weak staining was also detected in the regions of the presumptive eye through which the morphogenetic furrow had passed. In the dorsal prothoracic disc (which forms the humerus, mesothoracic spiracle, and pronotum, and for which a fate map has not been established), staining covered the half of the disc that is juxtaposed in the larva to the epidermis and spiracle (Fig. 4c). Because previous clonal analysis studies had indicated only that the entire humerus required *engrailed* function (Lawrence and Struhl 1982), the bipartite pattern of β -galactosidase expression in this disc is our first indication of the compartmental subdivision of the dorsal prothorax. The cuticle produced by these anterior and posterior compartment cells of the humeral disc are described below (Fig. 5). In the labial and genital discs, β -galactosidase expression was confined to a discrete, contiguously staining region in each case. Approximately one-half of the labial disc was β -galactosidase-positive, consistent with previous clonal analysis studies (Struhl 1981). The compartmental subdivision of the genital discs is not clear, although the β -galactosidase expression patterns (Fig. 4e,f) are generally consistent with previous clonal analysis studies (Lawrence and Struhl 1982; F. Epper and T. Kornberg, unpubl.). In addition to the prominent staining of the epidermal cells, weak staining was detected in discrete

Hama et al.

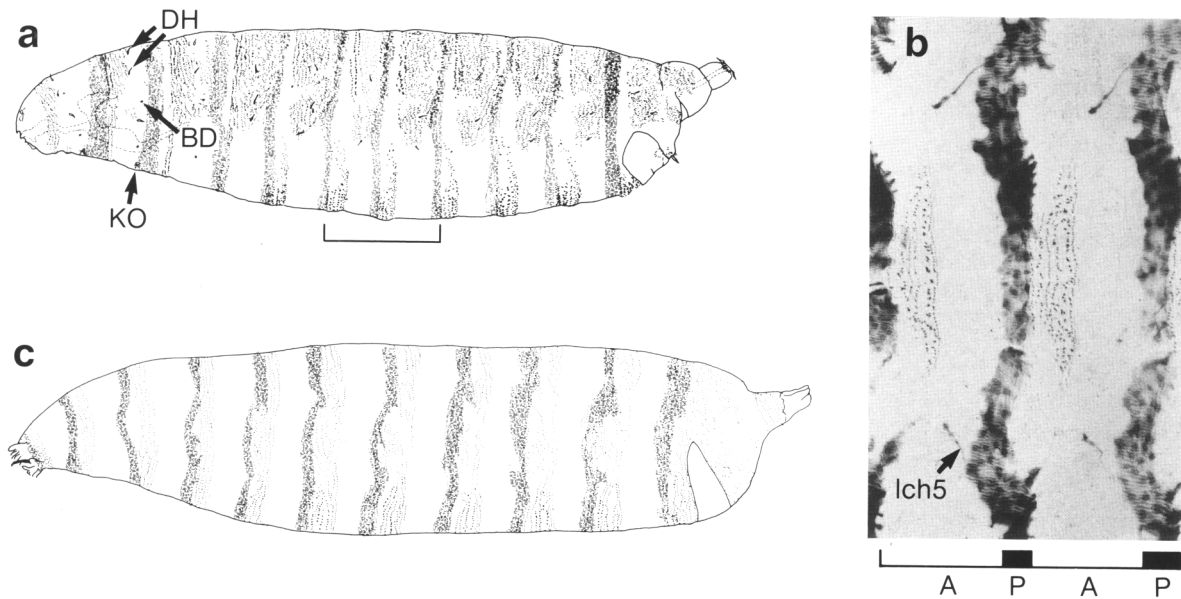

Figure 3. β -Galactosidase activity in the epidermis of first- and third-instar larvae of *rykho25*. β -Galactosidase activity is patterned in concentric rings that localize to the posterior compartments. Not indicated in the drawings of the first-instar (a) and third-instar (c) larvae is the peripheral nervous system expression in the chordotonal organs (*lch5*), which are prominent in the photomicrograph (b) of the bracketed portion of a first-instar larva. Anterior (A) and posterior (P) compartments are indicated in the photomicrograph.

regions of the peripodial membranes of the labial, wing, leg, and haltere discs (Fig. 4a).

β -Galactosidase activity in adults was in patterns that were, with few exceptions, consistent with the locations of posterior compartments that had been mapped previously by cell lineage analysis (Fig. 5). For instance, staining of the wing blade delineated a straight border slightly anterior to the fourth vein, where marked clones also define a boundary for growth (Fig. 5b; Garcia-Bellido et al. 1973, 1976). Similarly, posterior compartment identity of the proboscis (Struhl 1981), the humerus (Lawrence and Struhl 1982), the postscutellum, postscutum, postpleura, and pteropleura (Garcia-Bellido et al. 1973, 1976), the posterior portions of the legs (Steiner 1976; Lawrence et al. 1979), and the portion of the haltere sclerite extending through the inner surface of the pedicel to the capitellum (Garcia-Bellido et al. 1973, 1976) was confirmed by β -galactosidase staining (Fig. 5a,c). Several regions not detected by the previous studies also stained: The most anterior regions of the thorax derived from the dorsal prothoracic disc had discrete areas of β -galactosidase activity that encircled the anterior thorax completely (Fig. 5d). Staining was also present in the arista, the region surrounded by the ocelli, at the tips of the maxillary palps (Fig. 5c), in an internal clypeolabral derivative that overlies the posterior plate of the cibarium anteriorly, in the posterior region of the head that covers the occipital foramen, and in a portion of the rostral membrane (not shown). These regions presumably reflect previously undetected parts of posterior compartments.

The staining patterns of the larval and adult brains share a similar feature (not shown). Each brain hemi-

sphere had at least four groups of staining cells, although staining of the axonal tracts were noted in pupae. In the pupal and adult brains, the posterior portion of the subesophageal ganglion that connects to the thoracic ganglionic mass through the occipital foramen stained.

Staining in the adult abdomen indicates that the genitalia and abdominal segments are compartmentalized. In the male genitalia (not shown), the external genitalia (including the penis, penis mantle, and clasper and a thin band of the genital arch along the edge of the pons and joining with the clasper), the analia (including the dorsal portions of the anus and anal plate), and sperm pump expressed β -galactosidase and presumably identify posterior compartment cells. This conclusion is consistent with previous clonal analyses (Lawrence and Struhl 1982; F. Epper and T. Kornberg, unpubl.). In the female, expression was observed in the proximal region of the dorsal anal plate, uterus, vagina, and parovaria (not shown). In the abdominal segments, both the tergites and sternites are subdivided by bands of staining (Fig. 5c,d). Dorsally, the staining cells in each segment include the region of the cuticle posterior to the macrochaete that has hairs but not chaete and the intersegmental membrane (Fig. 5e). This suggests that the acrotergite is the most anterior part of each segment. The bands of staining cells do not include the pleural spiracles or the chaete of the sternites (Fig. 5e,f).

Recombination in the engrailed gene

The *engrailed* promoter is large, and we would expect that most of it is required to generate the normal patterns of *engrailed* expression. It was therefore surprising

that the β -galactosidase patterns of *ryxho25*, which were generated by a construct that contains only 5.7 kb of the promoter, approximated the *engrailed* program so closely. Whereas most of the transformed strains did not express β -galactosidase specifically in the posterior

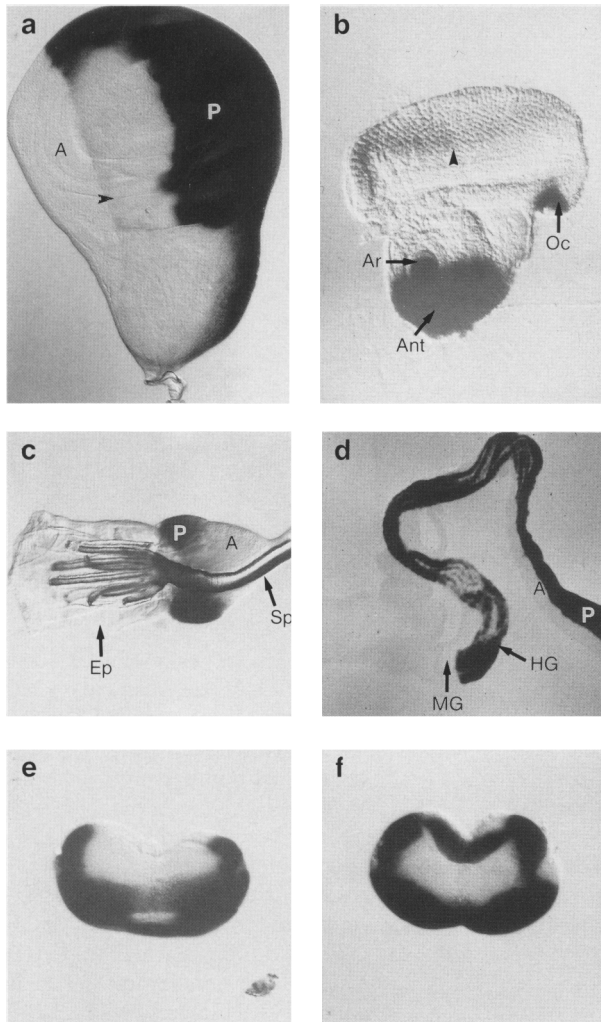

Figure 4. β -Galactosidase activity in imaginal discs and the hindgut of *ryxho25* larvae is largely confined to posterior compartments. (a) Most β -galactosidase activity in this wing imaginal disc is in the posterior compartment. The weakly stained area (indicated at its border by the arrowhead) may be associated with the periopodial membrane. (b) Most β -galactosidase activity in this eye-antennal imaginal disc is in the posterior compartment of the antenna (Ant) and arista (Ar). In addition, there is a region with intense staining in the area of the presumptive ocellus (Oc) and a region with light staining in the portion of the eye disc through which the morphogenetic furrow has passed (indicated by arrowhead). (c, e, and f) Staining in the humeral (c), male genital (e), and female genital (f) imaginal discs indicates the bicompartamental organization of these organs. (Ep) Epidermis; (Sp) spiracle. (d) Staining of one longitudinal half indicates the bicompartamental organization of the hindgut. The anterior limit of the staining precisely defines the boundary of the midgut (MG) and hindgut (HG). (A) Anterior compartment; (P) posterior compartment.

compartments, *ryxho25* was only one of several that did. To investigate this inconsistency, the cytological location of the integrated plasmids was determined in all of the transformed strains whose P elements segregated with the second chromosome, the location of the *engrailed* gene. Remarkably, most strains with posterior compartment expression of β -galactosidase had the *engrailed* region of the chromosome at polytene region 47F–48A as the common site of integration (Table 1).

In situ hybridization to polytene chromosomes and Southern analysis of chromosomal DNA indicated that two of the transformed strains with the 5.7-kb fragment (*ryxho23* and *ryxho25*) and one with the 7.5-kb fragment (*neosac27*) had integrated the fusion constructs in the *engrailed* gene. In addition, these strains failed to complement *engrailed* mutants (Fig. 6). For instance, heterozygotes of *ryxho23* with *en^{SFX31}*, a deletion of the *engrailed* region, *en^{LA7}*, an *engrailed* point mutation, or *en¹* had wing vein abnormalities. The phenotype of *ryxho25* was more extreme: It failed to survive with *en^{SFX31}* and had wing vein abnormalities similar to *en-point-lethal/en¹* flies. *ryxho25* homozygotes survived occasionally and had wings with similar defects. *rysac9* and *neosac71*, when heterozygous with *engrailed* mutations, have phenotypes similar to *ryxho23*. The *engrailed* phenotype of *neosac27* is similar to *ryxho25*, although *neosac27* carries two insertions on the second chromosome and is female sterile. Clearly, *engrailed* function encoded on the chromosomes with the inserted chimeric genes was affected by the presence of the integrated element. Patterns of β -galactosidase expression in the three strains were indistinguishable, with the exception that the hindgut of *neosac27* larvae expressed β -galactosidase in all of the hindgut cells.

To investigate the mechanism by which these strains had been transformed, two of the integrated elements were isolated in recombinant form. Sequence analysis of the junction regions of the inserts of *ryxho25* and *neosac27* revealed them to be 257 nucleotides upstream and 14 nucleotides downstream of the most distal *engrailed* initiation start site, respectively (Fig. 7a). Eight base pairs of genomic sequence were duplicated at each end of the inserts. Southern analyses indicated that the integrated constructs had lost the bacterial sequences that had been located between the P-element ends, suggesting that P-element functions had catalyzed their insertion into the genome. Therefore, the structure of the inserts suggests that integration was mediated by P-element functions and did not involve homologous recombination. Consistent with this result, no transformants were recovered after the 7.5-kb fusion construct was injected into >1000 embryos that had no source of P transposase. Further characterization indicated that the chimeric genes in *ryxho25* and *neosac27* are in opposite directions, with the *engrailed-lacZ* gene of *neosac27* in the same orientation as the resident *engrailed* gene.

In four additional strains, the recombinant P elements integrated into the region of *engrailed*, although not into the gene itself (Fig. 7a,b). *wxba21* had an insert in *inverted*, a gene that is closely related to *engrailed* in se-

Hama et al.

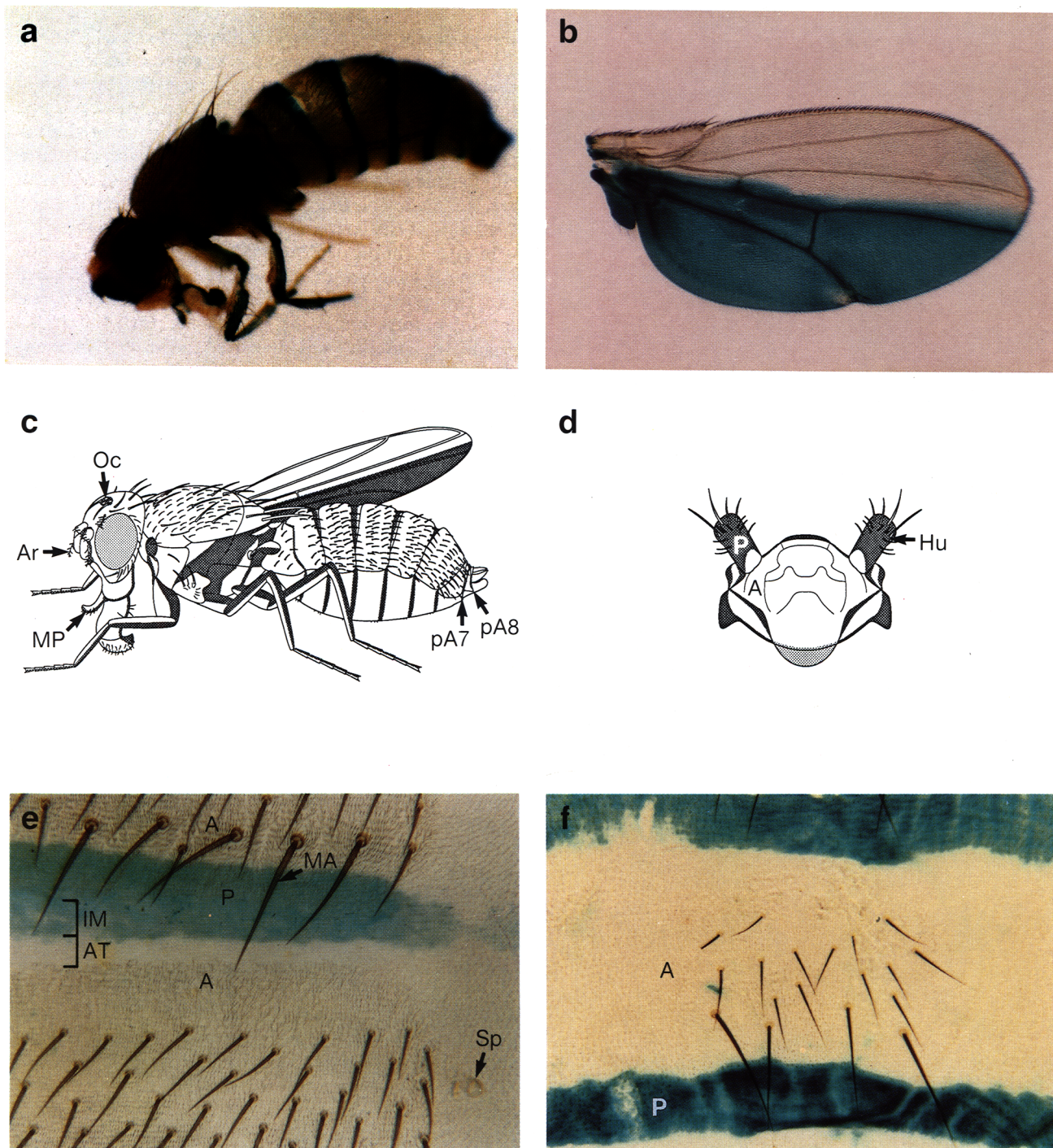

Figure 5. β -Galactosidase activity in the adult cuticle of *ryxho25* flies defines the posterior compartments. (a and b) Adult female and wing blade stained for β -galactosidase activity. (c) Drawing of stained adult female, indicating the patterns of β -galactosidase activity. In the head, these patterns largely agree with earlier mosaic studies with *engrailed* mutants, with the exception that β -galactosidase activity was observed in the arista (Ar), the ocellus (Oc), the maxillary palps (Mp), and the posterior head capsule (data not shown). Activity in the humerus (Hu) and cervical region is shown in d, and the location of the stripes of activity in the tergites and sternites is shown in e and f. (A) Anterior compartment; (P) posterior compartment; (Sp) spiracle; (IM) intersegmental membrane; (AT) acrotergite; (MA) macrochaete; (pA7) posterior compartment of A7; (pA8) posterior compartment of A8.

quence and pattern of expression and is juxtaposed and proximal to *engrailed* (Coleman et al. 1987). Sequence analysis indicated that the ends of the *wxba21* insert were joined to nucleotides -6 and $+2$ of the *invected*

transcription unit and that the 8 adjacent base pairs of the genome were duplicated at each end. Transcriptional orientation of the chimeric gene is the same as the resident *invected* gene. In the three other strains—*wxba9*,

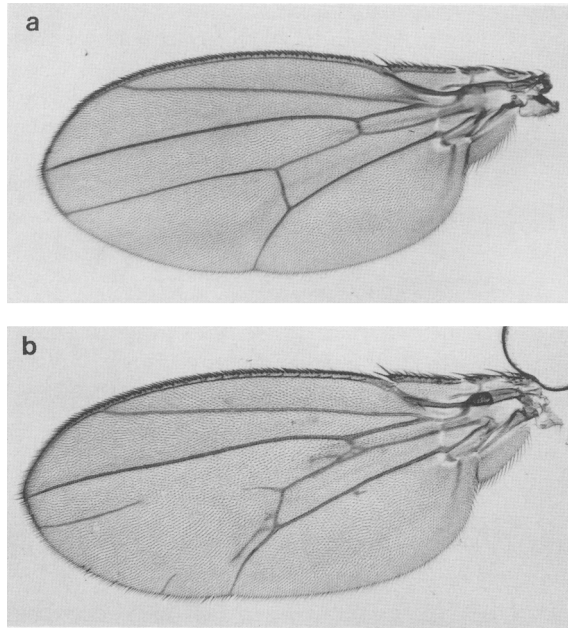

Figure 6. The wing phenotype of *ryxho25/en¹*. Comparison of photographs of wild-type (a) and mutant (b) wings reveals abnormalities in the fourth and fifth wing veins. These abnormalities are confined in the posterior compartment. Rare *ryxho25* homozygotes have a similar wing phenotype with occasional loss of bristles on scutellum and one haltere.

rysac9, and *neosac71*—the P elements were integrated in region 47E–F.

To summarize, among 20 strains transformed with chimeric genes containing 3.4, 5.7, or 7.5 kb of *engrailed* promoter sequence, 7 (henceforth referred to as 48A strains) integrated into the region of the *engrailed* gene. In contrast, among 16 strains transformed with chimeric

genes containing 1.1 kb of the *engrailed* promoter, none integrated into the 48A region.

Patterns of β -galactosidase expression depend on both position and sequence

Patterns of β -galactosidase activity in the transformed strains were determined. In 16 strains with 1-kb constructs, no activity was detected that was prominent or specific to *engrailed* promoter sequences (Table 1). Instead, a variety of patterns characterized the strains. A feature common to some of these strains was expression in the posterior–dorsolateral portion of each segment in germ-band-extended embryos. In many of these patterns, a cluster of stained cells was also visible at the ventral-most extension of each segmental stripe; however, we have not established that the segmentally repeated patterns of these strains is dependent on the 1 kb of *engrailed* sequence.

Among nine strains with 3.4 kb of *engrailed* promoter, only the two 48A strains had significant activity. Four transformed strains were recovered that carried constructs with 5.7 kb of the *engrailed* promoter, and two of these had inserts outside the *engrailed* region. One (*ryxho38* at 49D) had no significant activity; the other (*ryxho30* at 34E) had striped expression of β -galactosidase in the epidermis and ventral nervous system of embryos. These patterns of β -galactosidase activity were similar to those of the 48A strains, except that the *ryxho30* patterns alternated in intensity even after germ-band shortening. The 48A strains had patterns that alternated in intensity only during germ-band elongation and subsequently were of equal intensity. Neither *ryxho30* or *ryxho38* larvae had β -galactosidase activity that was prominent or specific to the posterior compartments of their imaginal discs.

Among the strains with 7.5-kb constructs, three of the

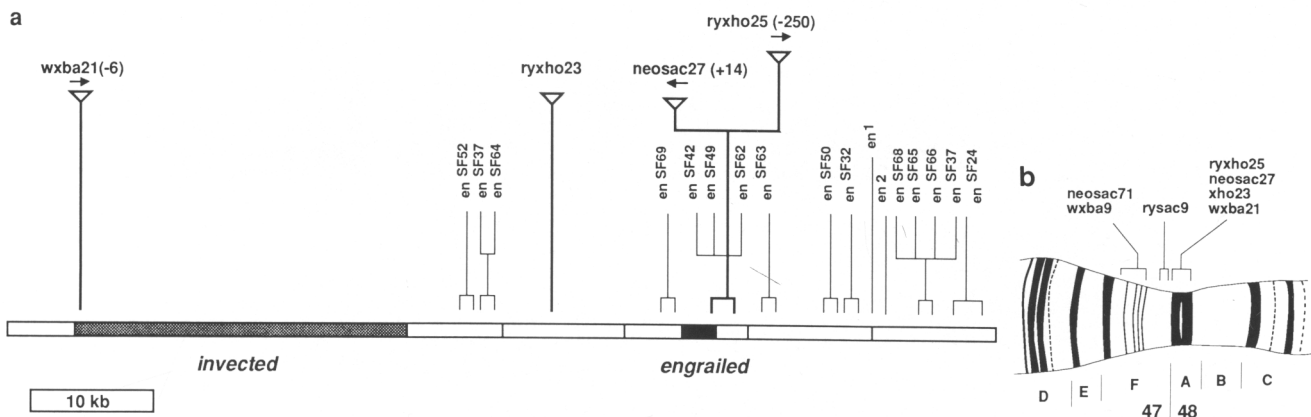

Figure 7. Location of *engrailed*-P-element insertions in the 48A region. (a) The double horizontal lines represent the genome and the blocked-in portions of the *engrailed* (solid) and *invected* (shaded) transcription units. The thick vertical lines with inverted triangles indicate the insertion sites of four *engrailed*-P elements. The numbers in parentheses indicate the distance in nucleotides from the nearest P-element end to the nearest transcription initiation site. The small arrows indicate the orientation of transcription of the *engrailed*-*lacZ* genes. The thin lines indicate the breakpoints of nearby *engrailed* mutations (Kuner et al. 1985). (b) The cytological locations of the *engrailed*-P-element insertions were determined after hybridization in situ with biotinylated *lacZ* DNA probes and are indicated.

Hama et al.

four non-48A strains had significant β -galactosidase activity. Strong expression in the embryos of *rysac37*, *wsac16*, and *wsac35* closely approximated the embryonic patterns of *ryxho25* in the epidermis and nervous system. Relative to *ryxho25*, however, expression progressed more slowly: The striped patterns of germ-band-extended embryos alternated in intensity and equalized only later. The 7.5-kb strains had no or little expression in the region of the procephalon and hindgut, respectively, and staining of the chordotonal organs and the ventral nervous system was weaker in the three strains. Imaginal disc expression in these strains was weak and was also strain dependent. Whereas expression in all *wsac16* discs was posterior-compartment-specific, only

the leg discs of *rysac37* flies and wing and haltere discs of *wsac35* flies had *engrailed*-like patterns. We conclude that within 7.5 kb of the proximal portion of the *engrailed* promoter, there is sufficient information to specify expression in most posterior compartments of the embryonic and imaginal tissues. The weak imaginal expression in these strains suggests that the 7.5 kb of upstream sequence lacks enhancers involved in promoting high-level expression in these tissues.

To investigate whether the mechanism by which the 7.5-kb segment directs the striped pattern in embryos is similar to that of the normal *engrailed* promoter, we examined the pattern of β -galactosidase activity of *wsac35* embryos that were mutant for genes known to affect *en-*

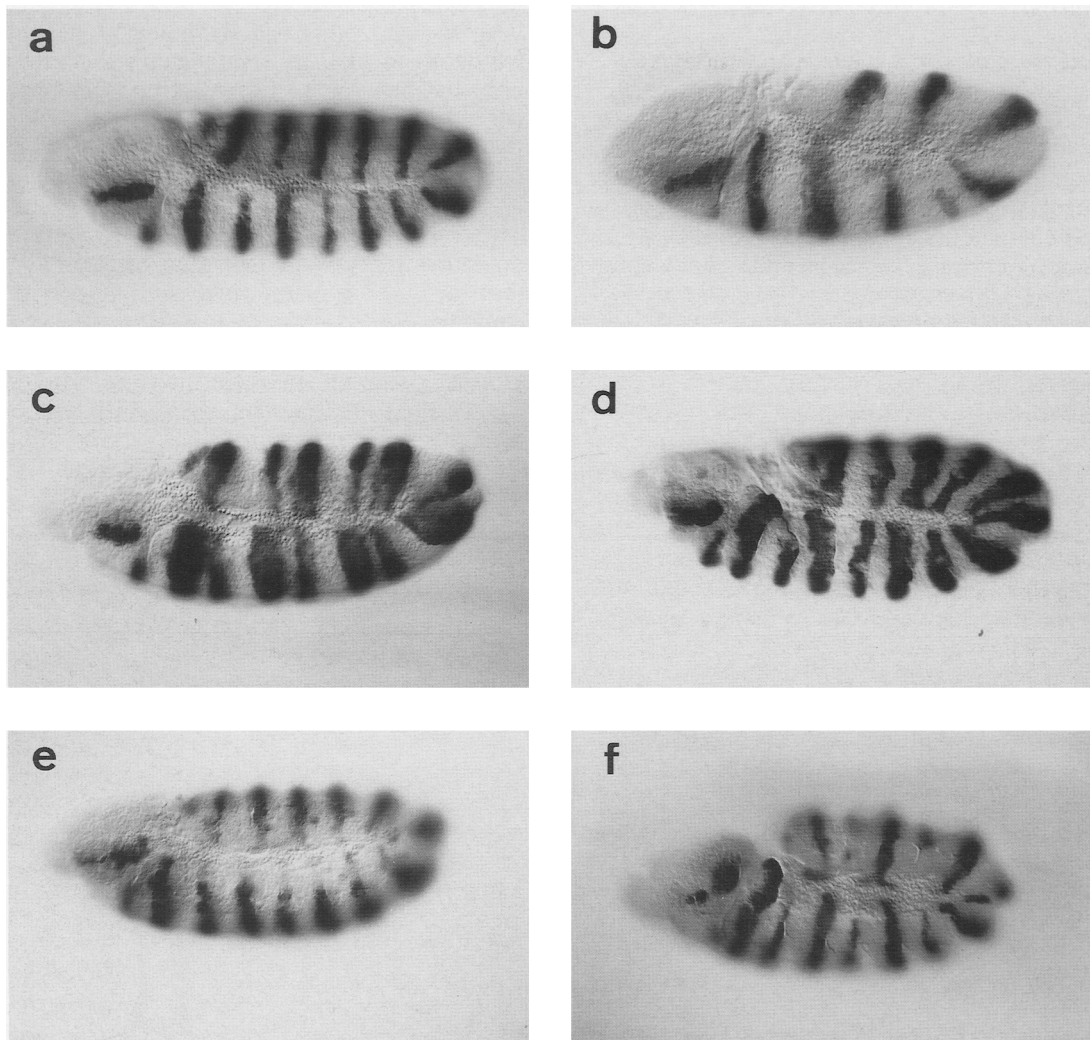

Figure 8. Patterns of β -galactosidase in *wsac35*, a strain carrying a chimeric *lacZ* gene fused to 7.5-kb *engrailed* flanking sequence. (a) A wild-type embryo, slightly older than that in Fig. 2c. Note that unlike the *ryxho25* embryo in Fig. 2c, the intensity of the stripes alternate, and no staining in a dot-shaped cell group in procephalon appears. (b) A 4-hr *h^{k1}* mutant embryo has eight stripes in the thoracic and abdominal primordia. The second stripe is abnormally broad, and the fourth is abnormally small. Older embryos (not shown) have more stripes. (c) An *odd^{111D36}* mutant embryo, ~5 hr. The even-numbered stripes extend more posteriorly than normal, making the stripes broader, whereas the odd-numbered stripes remain normal in size. Later, furrows separate the broad stripes into two portions. (d) A *nkd^{7E89}* mutant embryo (7.5 hr). Most stripes become broader than in wild type. Other strains carrying 7.5-kb constructs (*rysac37* and *wsac16*) in these mutant backgrounds had essentially the same expression patterns (e and f).

grailed expression (Howard and Ingham 1986; Macdonald et al. 1986; DiNardo and O'Farrell 1987; DiNardo et al. 1988; Martinez-Arias et al. 1988). For example, *engrailed* expression disappears in even- and odd-numbered parasegments of *fushi tarazu* (*ftz*) and *paired* (*prd*) mutants, respectively, and appears ectopically in *hairy* (*h*) and *odd-skipped* (*odd*) mutants. Related effects have been observed in mutants of *even-skipped* (*eve*), *naked* (*nkd*), *patched* (*ptc*), and *wingless* (*wg*). We found that the striped patterns of β -galactosidase activity in the embryonic epidermis of *wsac35* were altered in these mutants and that the observed effects were consistent with the responses of *engrailed* expression to these mutant backgrounds for examples of *h*, *odd*, and *nkd*, (see Fig. 8). Thus, regulation provided by the 7.5-kb fragment involves the direct or indirect action of the factors that normally control *engrailed* expression.

In addition, patterns of β -galactosidase in *engrailed* mutant embryos suggest that the "zebra-stripe" element is regulated directly or indirectly by *engrailed* itself. When patterns of β -galactosidase in *wsac35/+*, *wsac35/+;en^{LA7}/en^{LA7}*, and *wsac35/+;en^{SFX31}/en^{SFX31}* embryos were compared, stripes of β -galactosidase appeared in the expected segmentally-reiterated patterns characteristic of early *engrailed* expression (not shown). We conclude that *engrailed* function is not required to establish its initial patterns of expression. However, in the *en^{LA7}/en^{LA7}* mutant embryos (but not in the control embryos), stripes of β -galactosidase in the regions dorsal to the tracheal pits in the thoracic and abdominal segments disappeared during germ band extension (about 5.5 hr AEL; Fig. 8e). In the *en^{SFX31}/en^{SFX31}* embryos, expression was more variable: in some, expression was similar to *en^{LA7}/en^{LA7}*, whereas in others, the dorsolateral regions of the odd numbered stripes were absent (Fig. 8f). Because *engrailed* expression does not normally diminish at these stages, and because *engrailed* expression is not maintained in germ-band extended embryos in many *engrailed* mutant backgrounds (Weir and Kornberg 1985; E. Gustavson and T. Kornberg, unpubl.), we infer that

engrailed may have an autoregulatory role that sustains expression in the embryonic epidermis and that this role may differ in the even and odd numbered stripes.

Finally, we note that the fusion genes that integrated into the *engrailed* gene appear to be regulated in a manner that is almost indistinguishable from the normal gene. We conclude that the elements of the large *engrailed* promoter, which normally operate over long distances, can function even when the relative orientation or absolute distances from their target has changed.

Discussion

Region-specific integration of *engrailed*-P elements

We used recombinant P elements to insert *engrailed* promoter-lacZ gene fusions into the fly genome. Numerous previous studies indicated that P elements transpose efficiently and that transposition to particular loci varies from frequencies of $<10^{-6}$ to 10^{-2} (Engels 1983; Kidwell 1986). Among 400 transformants whose cytological locations have been mapped and reported, only 3 integrated in the 47EF-48AB region (Merriam et al. 1986), and none of the genes in the ~30-40 polytene bands in this region are frequent sites for P-element recombination. Yet, similar P-element constructs containing *engrailed* sequences frequently did insert in this region—7 of 36 lines in this study.

Integration in the *engrailed* region depended on the amount and/or identity of sequences in the transformation vector. For instance, none of 16 different lines with 1.1 kb of promoter sequence, but 7 of 20 with more flanking sequence, inserted into the *engrailed* region. Furthermore, subsequent studies with constructs containing other arrangements of the *engrailed* promoter confirmed a high frequency of targeted insertion (7 of 10 with constructs containing sequences 3-5 kb upstream of the *engrailed* transcription start site; 8 of 9 with constructs containing the structural gene, 7.5 kb of upstream and 3 kb of downstream sequence; C.-N. Chen and T. Kornberg, unpubl.) We are intrigued by these ex-

Table 2. Transformation frequencies with *engrailed*-lacZ fusion genes

Transposon	Embryos injected	Embryos hatched	Fertile adults	Transformed adults ^a	Transformants with inserts in <i>engrailed</i> region
<i>neoxba</i>	365	120	?	0 (0,0)	—
<i>neosac</i>	568	237	?	2 (0.35, 0.84)	2
<i>rystu</i>	550	251	?	18 (3.3, 7.2)	0
<i>ryxba</i>	370	218	105	4 (1.1, 1.8)	0
<i>ryxho</i>	513	263	?	4 (0.78, 1.5)	2
<i>rysac</i>	260	161	72	2 (0.77, 1.2)	1
<i>wstu</i>	324	274	?	11 (3.4, 4.0)	0
<i>wxba</i>	474	426	?	6 (1.3, 1.4)	2
<i>wbgl</i>	488	455	?	1 (0.20, 0.22)	ND ^b
<i>wsac</i>	472	418	?	3 (0.64, 0.72)	0
<i>pw8</i>	312	171	62	25 (8.0, 14.6)	ND

^aThe numbers in parentheses are percent of flies transformed relative to the numbers of embryos injected and hatched, respectively.

^bThe staining pattern of this transformant was not related to that of *engrailed* and its integration site was not determined (ND).

Hama et al.

amples of targeted mutagenesis and consider possible mechanisms.

Several observations indicate that the recombinants we obtained in the *engrailed* region were not mediated by a homologous mechanism. For instance, among >1000 embryos injected with the 7.5-kb fusion plasmid, but not coinjected with a helper plasmid to supply P transposase, no transformants were obtained. In addition, none of the 36 transformants we characterized retained those plasmid sequences that are bracketed by the P-element ends and that are normally deleted during P-element-mediated integration. Finally, the sequence of the junctions of three transformants included genomic 8-bp repeats, another feature characteristic of P-element-mediated integration. Because the *engrailed* region is not normally a frequent target for P-element integration and the frequency of transformation observed was so low as to indicate the elimination of a background of random integrations (Table 2), we conclude that the region-specific insertion observed was dependent on both P-dependent recombination and the *engrailed* sequences in our transformation constructs. We are aware of no precedent for such directed, but nonhomologous, recombination. We suggest that either sequence homologies provide sufficient affinity to attract the recombinant constructs to the 48A region or that the *engrailed* promoter has an abundance of binding sites for proteins that can bring together sequences that they recognize in the *engrailed* gene. Strongly influenced by their proximity to the 48A region, a high percentage of the elements apparently integrate in this portion of the chromosome via P-dependent functions. We designate the term "homing" to describe the tendency of these elements to locate near the site of their greatest homology.

An interesting feature of the strains with plasmids integrated in the *engrailed* region is their *engrailed*-like compartment-specific expression. For those strains with inserts in the *engrailed* or *invected* genes, it seems likely that expression of the inserts is regulated by adjacent promoter sequences that normally control the expression of *engrailed* and *invected*, respectively. Sensitivity to promoter context has been observed previously and has been used as a general method for screening the *Drosophila* genome for particular patterns of expression (O'Kane and Gehring 1987). For those plasmids integrated in the general region but outside of the immediate vicinity of *engrailed* and *invected*, compartment-specific expression patterns are more surprising (see *wxb9* in Table 1). We can offer no satisfying explanation except to postulate that either the influence of the *engrailed* and *invected* promoters can extend over these great physical distances or that numerous other genes in the *engrailed* region are also expressed specifically in the posterior compartments. In this regard, the suggestion (see above) that enhancer-binding proteins may bring together sequences that they recognize in the *engrailed* gene may be extended to include other loci that are regulated by the same proteins. Following this reasoning, integration of the transposons in genes related to *engrailed* may be a consequence of homing.

The *engrailed* promoter

Mutations that inactivate the *engrailed* gene can be located as much as 25 kb upstream or 15 kb downstream of the *engrailed* transcription unit. Because there are many sites that bind regulatory proteins in this region (Soeller et al. 1988; Han et al. 1989) and because many other segmentation genes have been implicated as regulators of *engrailed* expression (Ingham 1988), it is apparent that the *engrailed* promoter is both large and complex. Our preliminary analysis of the effects of *engrailed* mutations has revealed only a general outline of the organization of functions in the promoter (E. Gustavson, M.P. Weir, and T. Kornberg, unpubl.). Breakpoint mutations within the 1 kb adjacent to the 5' end of the transcription unit reduce transcription to undetectable levels. Expression is detectable in mutants with more distal breakpoints: It is normal in the clypeolabrum and hindgut and is present but greatly reduced in all ectodermal stripes and in the nervous system. Two alleles, *C2* and *SFX24*, located ~13 and 18 kb upstream of the transcription start site, respectively, have more expression in the even-numbered parasegments than in the odd-numbered ones. We conclude that sequence elements essential for transcription are present adjacent to the transcription start site and that control elements necessary for expression in the clypeolabrum and hindgut are within the transcription unit, to its 3' side, or close to its 5' end. Efficient striped expression at wild-type levels must require sequences at least 15 kb upstream.

Studies published previously indicated that sequences within the proximal 10.7 kb of the *engrailed* promoter can direct striped embryonic expression of *lacZ* fusion constructs (DiNardo 1988). Our observations with similar constructs indicate that control elements are located within 7.5 kb of the transcription start site that are sufficient to promote expression in the posterior compartments of the embryonic epidermis and ventral nervous system but not in the clypeolabrum, hindgut, a portion of the procephalon, or larval imaginal discs. We therefore assume that regulatory functions located within the proximal 7.5 kb include both a "zebra-stripe" element for expression in the posterior compartments and/or a region with embryo-specific enhancer activity. Further analysis of this "zebra-stripe" enhancer (C.N. Chen and T. Kornberg, unpubl.) indicates that stripes in the cephalic, thoracic, and abdominal segments are not individually regulated. This conclusion that is consistent with the phenotype of the mutants that break the chromosome in this region. In this respect, the organization of the *engrailed* promoter may be unlike that of the *h* and *eve* gene promoters, in which the different stripes appear to be separately controlled (Howard 1989; Goto et al. 1989; Harding et al. 1989).

Promoter function controlled by the proximal 7.5 kb differs from the normal program of *engrailed* gene activation with respect to low expression in imaginal discs and several embryonic tissues, low expression in the early gastrula, and delay until germ-band contraction for

expression of the stripes in the even- and odd-numbered parasegments to reach equal intensity. It is possible that all of these differences can be attributed to the absence of appropriate enhancer elements in these fusion constructs. For instance, it is possible that a separate enhancer sequence is essential for imaginal expression. Indeed, the mutant *en¹* has an insertion in the *engrailed* promoter 15 kb upstream of the transcription start site, which specifically affects adult structures, and this region of the promoter can, in promoter fusion constructs, efficiently direct posterior compartment-specific expression in imaginal discs (C.-N. Chen and T. Kornberg, unpubl.). Similarly, it is clear from the patterns of *engrailed* expression in many breakpoint mutants that expression of *engrailed* in the clypeolabrum and hindgut is unaffected by lesions that abolish expression in the ectoderm and nervous system.

engrailed is expressed during most of the fly developmental cycle in various patterns: apparently uniformly in the pre-blastoderm syncytium; in a striped array in the early gastrula; subsequently in the embryonic central and peripheral nervous system, hindgut, and clypeolabrum; and in a compartment-specific manner in the embryonic ectoderm. In larvae, it is expressed in the imaginal discs and histoblasts, central and peripheral nervous system, hindgut, and clypeolabrum. Our genetic and molecular genetic studies indicate that the *engrailed* promoter regulates expression with multiple spatially and temporally distinct programs and that the complexity of the *engrailed* promoter apparently is a reflection of these many ways in which the *engrailed* gene is used. Conceptualizing the program of *engrailed* expression simply in terms of initiation versus maintenance may be misleading, given the multitude of developmental programs that characterize its regulation.

Studies of *engrailed* expression in chordates, annelids, and other arthropods have led to the suggestion that *engrailed* and other *Drosophila* segmentation genes have been coopted to their role in segmentation and that their original role was in neurogenesis (Patel et al. 1989). This view, that evolution of segmentation in arthropods has been driven principally by changes in the regulation of preexisting genes rather than by gene duplication, is certainly consistent with the complexity of the *engrailed* promoter.

Experimental procedures

P-element-mediated transformation

Germ line transformation was carried out essentially as described by Rubin and Spradling (1982). Embryos were injected with 300–600 µg/ml of the different constructs and, to provide transposase, 150 µg/ml of pπ25.7 wc (Karess and Rubin 1984).

Drosophila strains

For *P*-element-mediated transformation, *ry⁵⁰⁶* embryos were injected with pUCHsneo (Steller and Pirrotta 1985) or Carnegie 20 (Rubin and Spradling 1983) derivatives, and *Df(1)w67c23 y* embryos were injected with derivatives of pw8 (Klemenz et al.

1987). Inserts in transgenic flies were mapped genetically by crossing to appropriately marked strains. For fine-mapping strains with second chromosome insertions, in situ hybridization was carried out with probes for the *lacZ* gene. Polytene chromosome squashes, biotinylation of probes, and hybridization were performed according to E. Hafen (pers. comm.). For genetic analysis of strains with second chromosome inserts, heterozygotes were generated with the *engrailed* alleles *en¹* (viable), *en^{LA7}*, and *en^{SFX31}* (both lethal; Kornberg 1981a), and lethality and the wing phenotype were scored.

Plasmid construction

The *E. coli lacZ* gene was cloned into pUCHsneo as a *Bam*HI fragment from pMC1871. The orientation of the insert placed the carboxyl terminus of *lacZ* adjacent to the *Sal*I site in the polylinker of the vector. The carboxy-terminal *Bam*HI site was then removed, and a new polylinker sequence, GATC-CATGGTCTAGAGCTCCGCGGAATT, containing *Bam*HI, *Nco*I, *Xba*I, *Sac*I, *Sac*II, and *Eco*RI restriction sites was introduced between the *Bam*HI and *Eco*RI sites at the amino-terminal end of the *lacZ* gene to produce pUCneolac. To generate *engrailed-lacZ* fusion genes, a new *Bam*HI site was created in the *engrailed* sequence by use of oligonucleotide mutagenesis to change the G residue of the seventeenth nucleotide in the *engrailed* protein-coding sequence to C. The resulting fusion proteins contained the initial 5 amino acids of the *engrailed* protein in addition to all but the 8 amino-terminal amino acids of β-galactosidase. Promoter fragments joined to the fusion construct terminated at the *Stu*I, *Xba*I, *Xho*I, and *Sac*II sites, which demarcate –0.85, –3.2, –5.5, and –7.3 kb, respectively, from the transcription initiation site of *engrailed*. To move the constructs into Carnegie 20 (Rubin and Spradling 1983) and pw8 (Klemenz et al. 1987), the *Sac*II–*Sal*I fragment containing 7.5 kb *engrailed* upstream, leader, and amino-terminal protein-coding sequences and the *lacZ* sequence inserted in pUCneolac was digested with *Sal*I and appropriate restriction enzymes, filled in when necessary, and ligated to appropriately digested vector.

Southern hybridization and sequencing

Preparation of fly DNA and Southern analysis was as described previously (Kuner et al. 1985). To locate the integration sites of the strains with inserts in the 48AB region, probes from phage genomic clones encompassing ~200 kb of the 48AB region were generated by use of random primers and hybridized to fly genomic Southern blots. Four strains, *wxba21*, *rykho23*, *rykho25*, and *neosac27*, were found to carry the inserts in this region. The precise insertion sites of *wxba21*, *rykho25*, and *neosac27* were determined by isolation of relevant clones from partial Sau3A libraries made in EMBL 3 and sequencing by use of a 20-mer oligonucleotide (CGACGGGACCACCTTATGTT) from the inverse repeated sequence of the P-element ends as primer.

Staining of embryos, larvae, and adult flies

Unless indicated otherwise, stained animals were heterozygous and carried a single copy of integrated transposon. Dechorionation and fixation of embryos were done as described by Mitchison and Sedat (1983), with some modifications. Collected embryos were dechorionated in a 50% bleach solution for 90 sec and transferred to a tube containing a fixative composed of 0.2 ml of 38% formaldehyde, 1.8 ml of PEM buffer (0.1 M PIPES, 1 mM MgCl₂, and 1 mM EGTA, adjusted to pH 6.9 with KOH), and 2 ml of heptane. After shaking vigorously for 30 min, the lower aqueous phase was aspirated, and methanol was added to

Hama et al.

remove the vitelline membrane, followed by vigorous hand agitation for 10 sec. All of the solution was then aspirated, and the embryos were rinsed three times with methanol and three times with PBTK [50 mM NaH₂PO₄ (pH 7.3), 5 mM KCl, 50 mM NaCl, 0.2% BSA, and 0.1% Triton X-100]. For staining with antibody, the embryos were transferred to a solution containing a 10% normal goat serum and 1 : 1000 to 1 : 5000 diluted rabbit anti- β -galactosidase IgG (Cappel) in PBTK, incubated for 45 min with shaking, then rinsed three times, incubated for 45 min with rotation, and again rinsed three times, all in PBTK. Biotinylated goat anti-rabbit IgG (Vector), diluted to 1 : 200, and streptavidin-horseradish peroxidase conjugate (BRL), diluted to 1 : 200 in PBTK, were used for secondary and tertiary reactions. Each step was done as described for the primary reaction. The peroxidase reaction was carried out in PBTK with 170 μ g/ml diaminobenzidine and 0.06% hydroxyperoxide. Stained embryos were dehydrated in ethanol, cleared in methyl salicylate, and mounted in methyl salicylate-Canada balsam mixture. Imaginal discs, larval hindgut, and adult integuments were fixed with 0.2% EM-grade glutaraldehyde in PBS (130 mM NaCl, 7 mM Na₂HPO₄, and 3 mM NaH₂PO₄) for 2 min on ice, washed with PBS, and incubated in X-gal solution [0.2% 5-bromo-4-chloro-3-indolyl- β -D-galactopyranoside, 0.15 M NaCl, 1.0 mM MgCl₂, 5 mM K₄[Fe(CN)₆], 5 mM K₃[Fe(CN)₆], and 10 mM sodium pyrophosphate (pH 7.0), according to Simon et al. (1985), with a slight modification] from 5 hr to overnight at 37°C. For adult integuments, all steps were carried out by injecting each solution before placing the tissue in X-gal solution. Wings were dissected from freshly eclosed flies, submerged in 50% EM-grade glutaraldehyde, immediately washed with PBS, and stained in X-gal solution overnight.

Acknowledgments

We are grateful to Stephen Poole, Walter Soeller, Michael Weir, Elizabeth Gustavson, Tim Karr, and Kevin Coleman for state-of-the-art technical instructions, stimulating suggestions, and encouragement. We thank Kevin Coleman for cloning insertion sequences for some transformants and Rolf Bodmer and Steve McKnight for helpful comments. We thank Susan Shepard, Todd Laverty, and Rolf Bodmer for fly strains and Mary Mullins and Frank Laski for gifts of P-element plasmids. This work was supported by a Weingart Foundation Fellowship to C.H. and a National Institutes of Health grant to T.B.K.

The publication costs of this article were defrayed in part by payment of page charges. This article must therefore be hereby marked "advertisement" in accordance with 18 USC section 1734 solely to indicate this fact.

References

Bodmer, R. and Y.N. Jan. 1987. Morphological differentiation of the embryonic peripheral neurons in *Drosophila*. *Wilhelm Roux's Arch. Dev. Biol.* **196**: 69–77.

Brower, D. 1986. *engrailed* gene expression in *Drosophila* imaginal discs. *EMBO J.* **5**: 2649–2656.

Busturia, A. and G. Morata. 1988. Ectopic expression of homeotic genes caused by the elimination of the *Polycomb* gene in *Drosophila* imaginal epidermis. *Development* **104**: 713–720.

Coleman, K.G., S.J. Poole, M.P. Weir, W.C. Soeller, and T.B. Kornberg. 1987. The *invected* gene of *Drosophila*: Sequence analysis and expression studies reveal a close kinship to the *engrailed* gene. *Genes Dev.* **1**: 19–28.

DiNardo, S. and P.H. O'Farrell. 1987. Establishment and refinement of segmental pattern in the *Drosophila* embryo: Spatial control of *engrailed* expression by pair-rule genes. *Genes Dev.* **1**: 1212–1225.

DiNardo, S., J. Kunder, J. Theis, and P. O'Farrell. 1985. Development of embryonic pattern in *D. melanogaster* as revealed by accumulation of the nuclear *engrailed* protein. *Cell* **43**: 59–69.

DiNardo, S., E. Sher, J. Heemskerk-Jongens, J. Kassis, and P. O'Farrell. 1988. Two-tiered regulation of spatially patterned *engrailed* gene expression during *Drosophila* embryogenesis. *Nature* **332**: 604–609.

Drees, B., Z. Ali, W. Soeller, K. Coleman, S. Poole, and T. Kornberg. 1987. The transcription unit of the *Drosophila engrailed* locus: An unusually small portion of a 70,000 bp gene. *EMBO J.* **6**: 2803–2809.

Engels, W.R. 1983. The P family of transposable elements in *Drosophila*. *Annu. Rev. Genet.* **17**: 315–344.

Fjose, A., W. McGinnis, and W. Gehring. 1985. Isolation of a homeobox-containing gene from the *engrailed* region of *Drosophila* and the spatial distribution of its transcript. *Nature* **313**: 284–289.

Garcia-Bellido, A. 1975. Homoeotic and atavic mutations in insects. *Am. Zool.* **17**: 613–629.

Garcia-Bellido, A., P. Ripoll, and G. Morata. 1973. Developmental compartmentalization of the wing disk of *Drosophila*. *Nature New Biol.* **245**: 251–253.

———. 1976. Developmental compartmentalization of the wing disk of *Drosophila*. *Dev. Biol.* **48**: 132–147.

Goto, T., P. MacDonald, and T. Maniatis. 1989. Early and late periodic patterns of *even-2* *skipped* expression are controlled by distinct regulatory elements that respond to different spatial cues. *Cell* **57**: 413–422.

Han, K., M.S. Levine, and J.L. Manley. 1989. Synergistic activation and repression of transcription by *Drosophila* homeobox proteins. *Cell* **56**: 573–583.

Harding, K., T. Hoey, R. Warrior, and M. Levine. 1989. Autoregulatory and gap gene response elements of the *even-skipped* promoter of *Drosophila*. *EMBO J.* **8**: 1205–1212.

Hiroimi, Y., and W.J. Gehring. 1987. Regulation and function of the *Drosophila* segmentation gene *fushi tarazu*. *Cell* **50**: 963–974.

Howard, K. and P. Ingham. 1986. Regulatory interactions between the segmentation genes *fushi tarazu*, *hairy*, and *engrailed* in the *Drosophila* blastoderm. *Cell* **44**: 949–957.

Howard, K., P. Ingham, and C. Rushlow. 1988. Region-specific alleles of the *Drosophila* segmentation gene *hairy*. *Genes Dev.* **2**: 1037–1046.

Ingham, P.W. 1988. The molecular genetics of embryonic pattern formation in *Drosophila*. *Nature* **335**: 25–34.

Jürgens, G., R. Lehmann, M. Schardin, and C. Nüsslein-Volhard. 1986. Segmental organization of the head in the embryo of *Drosophila melanogaster*. A blastoderm fate map of the cuticle structure of the larval head. *Wilhelm Roux's Arch. Dev. Biol.* **195**: 359–377.

Karess, R.E. and G.M. Rubin. 1984. Analysis of P transposable element functions in *Drosophila*. *Cell* **38**: 135–146.

Karr, T.L., M.J. Weir, Z. Ali, and T. Kornberg. 1989. Patterns of *engrailed* protein in early *Drosophila* embryos. *Development* **105**: 605–612.

Kidwell, M.G. 1986. *P-M mutagenesis*. pp. 59–81, IRL Press.

Klemenz, R., U. Weber, and W.J. Gehring. 1987. The *white* gene as a marker in a new P-element vector for gene transfer in *Drosophila*. *Nucleic Acids Res.* **15**: 3947–3959.

Kornberg, T. 1981a. *engrailed*: A gene controlling compartment and segment formation in *Drosophila*. *Proc. Natl.*

- Acad. Sci.* **78**: 1095–1099.
- . 1981b. Compartments in the abdomen of *Drosophila* and the role of the *engrailed* locus. *Dev. Biol.* **86**: 363–381.
- Kornberg, T., I. Siden, P. O'Farrell, and M. Simon. 1985. The *engrailed* locus of *Drosophila*: In situ localization of transcripts reveals compartment-specific expression. *Cell* **40**: 45–53.
- Kuner, J., M. Nakanishi, Z. Ali, B. Drees, E. Gustavson, J. Theis, L. Kauvar, T. Kornberg, and P. O'Farrell. 1985. Molecular cloning of *engrailed*, a gene involved in the development of pattern in *Drosophila melanogaster*. *Cell* **42**: 309–316.
- Lawrence, P.A. and G. Struhl. 1982. Further studies on the *engrailed* phenotype in *Drosophila*. *EMBO J.* **1**: 827–833.
- Lawrence, P.A., G. Struhl, and G. Morata. 1979. Bristle patterns and compartment boundaries in the tarsi of *Drosophila*. *J. Embryol. Exp. Morphol.* **51**: 195–208.
- Macdonald, P., P. Ingham, and G. Struhl. 1986. Isolation, structure, and expression of *even-skipped*: A second pair-rule gene of *Drosophila* containing a homeo box. *Cell* **47**: 721–734.
- Martinez-Arias, A., N. Baker, and P. Ingham. 1988. Role of segment polarity genes in the definition and maintenance of cell states in the *Drosophila* embryo. *Development* **103**: 157–170.
- Merriam, J., S.L. Smalley, A. Merriam, and B. Dawson. 1986. The molecular genome of *Drosophila melanogaster*. Catalogs of cloned DNA, breakpoints and transformed inserts by chromosome location. *Drosophila Inf. Ser.* **63**: 173–264.
- Mitchison, T.J. and J. Sedat. 1983. Localization of antigenic determinants in whole *Drosophila* embryos. *Dev. Biol.* **99**: 261–264.
- Morata, G. and P.A. Lawrence. 1975. Control of compartment development by the *engrailed* gene in *Drosophila*. *Nature* **255**: 614–617.
- . 1979. Development of the eye-antenna imaginal disc of *Drosophila*. *Dev. Biol.* **70**: 355–371.
- O'Kane, C.J. and W.J. Gehring. 1987. Detection in situ of genomic regulatory elements in *Drosophila*. *Proc. Natl. Acad. Sci.* **84**: 9123–9127.
- Patel, N.H., E. Martin-Blanco, K.G. Coleman, S.J. Poole, M.C. Ellis, T.B. Kornberg, and C.S. Goodman. 1989. Expression of *engrailed* proteins in arthropods, annelids, and chordates. *Cell* **58**: 955–968.
- Poole, S.J. and T.B. Kornberg. 1988. Modifying the expression of the *engrailed* gene of *Drosophila melanogaster*. In *Mechanisms of segmentation* (ed. V. French, P. Ingham, J. Cooke and J. Smith), pp. 85–93. The Company of Biologists, Cambridge.
- Poole, S.J., L. Kauvar, B. Drees, and T. Kornberg. 1985. The *engrailed* locus of *Drosophila*: Structural analysis of an embryonic transcript. *Cell* **40**: 37–43.
- Roseland, C.R. and H.A. Schneiderman. 1979. Regulation and metamorphosis of the abdominal histoblasts of *Drosophila melanogaster*. *Wilhelm Roux's Arch. Dev. Biol.* **186**: 235–265.
- Rubin, G.M. and A.C. Spradling. 1982. Genetic transformation of *Drosophila* with transposable element vectors. *Science* **218**: 348–353.
- . 1983. Vectors for P element-mediated gene transfer in *Drosophila*. *Nucleic Acids Res.* **11**: 6341–6351.
- Soeller, W.C., S.J. Poole, and T.B. Kornberg. 1988. In vitro transcription of the *Drosophila engrailed* gene. *Genes Dev.* **2**: 68–81.
- Steiner, E. 1976. Establishment of compartments in the developing leg imaginal discs of *Drosophila melanogaster*. *Wilhelm Roux's Arch. Dev. Biol.* **180**: 9–30.
- Steller, H. and V. Pirotta (1985). A transposable P vector that confers selectable G418 resistance to *Drosophila* larvae. *EMBO J.* **4**: 167–171.
- Struhl, G. 1981. Anterior and posterior compartments in the proboscis of *Drosophila*. *Dev. Biol.* **84**: 372–385.
- . 1984. Splitting the bithorax complex of *Drosophila*. *Nature* **308**: 454–457.
- Szabad, J., T. Schüpbach, and E. Wieschaus. 1979. Cell lineage and development in the larval epidermis of *Drosophila melanogaster*. *Dev. Biol.* **73**: 256–271.
- Weir, M.P. and T. Kornberg. 1985. Patterns of *engrailed* and *fushi tarazu* transcripts reveal novel intermediate stages in *Drosophila* segmentation. *Nature* **318**: 433–439.
- Weir, M.P., B.A. Edgar, T. Kornberg, and G. Schubiger. 1988. Spatial regulation of *engrailed* expression in the *Drosophila* embryo. *Genes Dev.* **2**: 1194–1203.